

Exhaust Baffel
*Sound Attenuation
Only

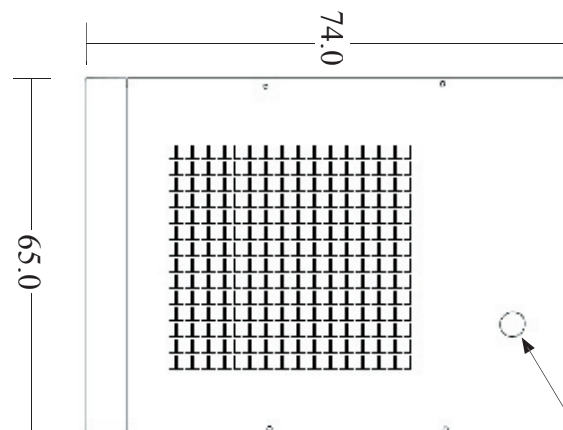

Exhaust Out 4.0"

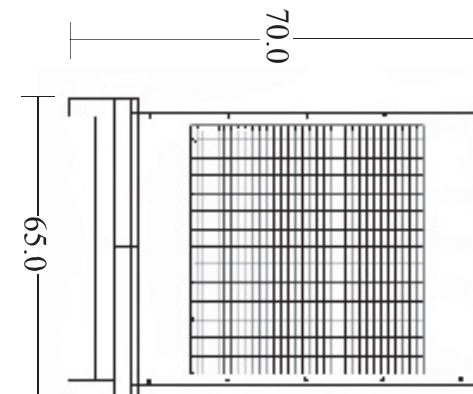
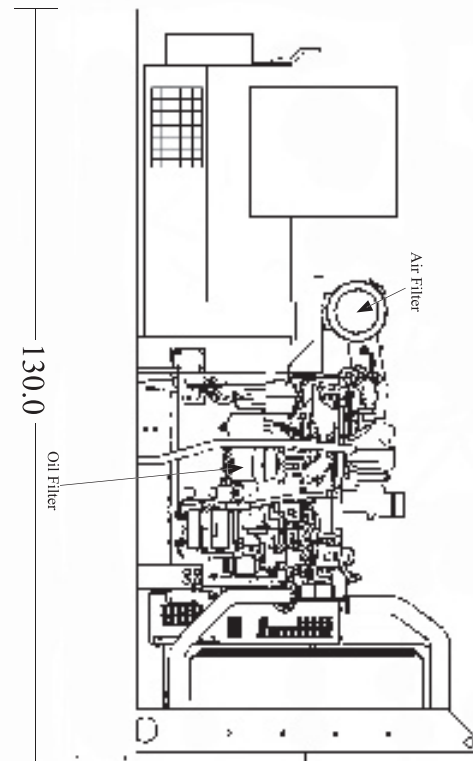

300kW_{60Hz} 313kVA_{50Hz}

norpro®

A Global Power Solutions Company

Power Max Series

2/18/08

300PMJ

Standby Rating 60Hz: 300kW
Prime Rating 60Hz: 270kW

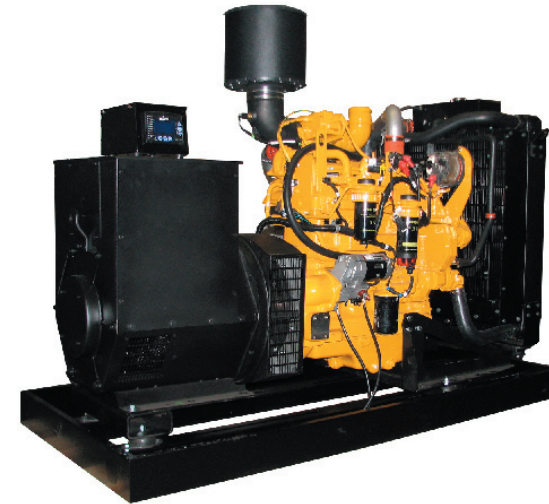

Philosophy at Norpro

- Build a reliable product for the harshest of operating environments.
- Supply a product which is simple to operate and easy to maintain
- Use the best technology and materials available
- Provide the best value in the industry

More For Your Money

Norpro has been a leader in generator technology since we began operations in 1986. We strive to provide the best in terms of durability, performance, and value in the generator market. Using only world-class engines and components, we hand build the highest quality generators possible. By using high grade materials including, epoxy paint, stainless hardware, and powder coat, you can rest assured your generator will look good for many years to come. Our sound shields were developed using input from the aerospace industry. The results speak quietly on their own with sound canceling effects decreasing noise on average by 50%. We are very committed and proud of our product which is why we offer one of the most extensive warranties available. With the support of an experienced warranty representative, and a multi-million dollar inventory, all your generator needs are just a phone call away. Sales and services are handled by factory trained distributors and dealers reaching across the country and around the world. Everything is done to help us meet your needs and exceed your expectations.

Standard Features

- Radiator Cooled Genset
- Muffler
- Air Filter
- Steel Skid Base
- Steel Fan Gaurd
- Rubber Isolation Mounts
- Battery Tray
- Battery Cables and Hold Down
- Battery Charger (3 amp)
- Oil Drain Kit
- Digitec 400 Control Panel
- Hand Built in the USA
- Prototype and Production Tested
- Meets or Exceeds Tier 3 Nonroad Emissions Regulations
- 2 Year 2,000 Hour Warranty

Digitec 400 Controller

- Programmable microprocessor panel
- Engine start up with an automatic preheat system
- Digital display
- Most vivid LCD screen available
- Automatic battery recharge
- Eight digital programmable inputs
- Twenty-five programmable digital outputs
- Automatic shutdown for any discrepancy in:
 - current
 - speed
 - voltage
 - frequency
 - battery levels
- Password protected
- Fully programmable engine exerciser
- 100 event failure log
- Connection for six industry standard analog senders
- Sleep mode to conserve battery
- 5.47" x 4.45" x 2.56" (L x H x D)



Complete details also available on our website.
Please visit www.4norpro.com

Engine Specifications	60Hz	50Hz
Manufacturer	John Deere	
Engine model	6135HF485	
Cylinder arrangement	6 in line 4-cycle	
Displacement, cu.in. (cc)	824 (13500)	
Bore and stroke, in. (mm)	5.2 (132) x 6.5 (165)	
Compression ratio	16.0:1	
Rated rpm	1800	1500
Max power at rated rpm (bhp)	463	386
Cylinder head material	Cast Iron	
Block material	Cast Iron	
Governor type	Electrical	
Frequency regulation	±0.25%	
Air cleaner type	Cartridge	

Engine Electrical System

Ignition system	Electric	
Battery charging system voltage (DC)	12V or 24V	
Battery charging system (amps)	45	
Starter system voltage (DC)	12V or 24V	
Battery recommendation (CCA)	Two, 950	
Battery voltage (DC)	12V	
Starter kW	14.5	

Generator Specifications

Type	4 Pole	
Exciter type	Brushless	
Leads: Quantity	12	
Voltage regulator	AVR	
Insulation material	H type	
Temperature rise	105° C	
Bearing type	Sealed	
Coupling	Direct Bolt-up	
Voltage regulation	1%	
Phase type	1 or 3	
Power factor	1.0 or 0.8	
Power rating kW	300	250
Power rating kVA-1.0 (0.8)	300 (375)	250 (313)

Generator Ratings

Single Phase 1.0 PF		
Amps @ 120V	2500	2083
Amps @ 240V	1250	1042
Three Phase 0.8 PF		
Amps @ 120V	1804	1504
Amps @ 127V	1705	1421
Amps @ 208V	1041	867
Amps @ 240V	902	752
Amps @ 277V	782	651
Amps @ 416V	520	434
Amps @ 480V	451	376

Lubrication System	60Hz	50Hz
Type	Full Pressure	
Engine oil capacity w/filter, qt.(L)	40 (37.9)	
Oil filter type	Cartridge	

Fuel System

Fuel shutoff solenoid	Electric
Fuel pump	Electric
Fuel pump priming	Electric
Fuel type	#2 Diesel
Fuel pump lift, ft (m)	9.9 (3.0)
Fuel line supply (in)	1/2
Fuel line return (in)	3/8

Cooling System

Engine coolant capacity, qt. (L)	3.1 (2.9)
Radiator coolant capacity, qt. (L)	19 (18)
Water pump type	Centrifugal
Fan diameter, in. (cm)	37 (94)
Fan & Alternator (hp)	16.5
Fan type	Pusher
Fan rotation from front of engine	Clockwise

Air Requirements

Engine combustion air intake (cfm)	1050
Generator end cooling (cfm)	2115
Sound shield air space, in. (cm)	18 (46)

Exhaust System

Exhaust type	Residential Muffler
Max allowable back pressure (kpa)	7.5
Exhaust outlet size, in.(cm)	3.86 (98)

Fuel Consumption @ Prime Rating

100% Load, gph (lph)	19.8 (75.0)
75% Load, gph (lph)	15.0 (56.8)
50% Load, gph (lph)	10.9 (41.3)

Fuel Consumption @ Standby Rating

100% Load, gph (lph)	22.0 (83.3)
75% Load, gph (lph)	16.6 (62.8)
50% Load, gph (lph)	11.8 (44.7)

Sound Tables

dB(A) Without Sound Shield			
Load	100%	75%	50%
3'	90	89	87
10'	84	84	83
21'	79	79	78

dB(A) With Sound Shield			
Load	100%	75%	50%
3'	77	78	77
10'	75	75	72
21'	69	69	68

Weights and Dimensions

	Length in. (cm)	Height in. (cm)	Width in. (cm)	Dry Weight lbs. (kg)	Wet Weight lbs. (kg)
Open Unit	130 (330)	70 (178)	65 (165)	6260 (2839)	6335 (2874)
Enclosed	130 (330)	74 (188)	65 (165)	6660 (3021)	6735 (3055)
Open w/Sub. Tank	130 (330)	Varies by Capacity	65 (165)	Varies by Capacity	Varies by Capacity
Stand Alone Fuel Tanks					
165 gal./620L	29 (74)	61 (155)	28 (72)	132 (60)	1287 (584)
275 gal./1000L	51 (130)	54 (137)	30 (76)	208 (94)	2133 (968)

OPTIONAL EQUIPMENT

Remote Start Panel

- Starting and stopping capabilities from a remote location

Color Options

- Bonsai Blue
- Zodiac Blue
- Midnight Black
- Anthracite Gray
- Soft Silver

Enclosures

- Protects from the elements
- Decrease noise while maintaining airflow
- Sophisticated polyether foam adds further sound deadening on sound enclosures
- Foam is UL 94 HF1 listed for flammability testing
- All aluminum (stainless steel hardware)
- 5052 .080 aluminum
- Powder coated to ensure a long lasting finish
- Complete teardown in minutes using only a # 2 philips screwdriver
- Doors come off/open via durable Southco latches
- Add sound attenuation for more sound cancelling

Fuel Tanks

- Sub-base mounted single wall tank
- Sub-base mounted, UL listed, double wall tank
- Stand alone, UL Listed, double wall tank, 165 gal. (620 L)
- Stand alone, UL Listed, double wall tank, 275 gal. (1000 L)

More Options

- Battery
- Critical muffler kit
- 24V kit
- D.O.T. trailer
- Interlocking mounts
- Manual transfer switch
- Automatic transfer switch
- Mainline breaker
- Inline style block heater
- Cartridge type air filter